

ACE

Electric Stacker (ES)

Capacity : 1.5 T - 2.0T

High Performance & rugged
Electric Stacker

ACE INDIA'S NO. 1
CRANE BRAND



PROPERTIES	DESCRIPTION		UNIT	TECHNICAL SPECIFICATIONS	
	Model			ES15	ES20
Identification	Type of Drive			Fully Electric	
	Capacity	Q	Kg	1500	2000
	Lift Height	H3	MM	3000	
	Load Center	C	MM	600	
	Service Weight (apx.)		Kg	1090	1380
	Wheel Type			Polyurethane	
Performance	Travel Speed (Laden/Unladen)		km/h	5 / 5.3	
	Lift Speed (Laden/Unladen)		MM/s	58/148	
	Lower Speed(Laden/Unladen)		MM/s	145/80	
	Gradeability(Laden/Unladen)		%	5/7	
	Service Brake			Electromagnetic	
Power	Drive Motor		Kw	1.5	2.2
	Lift Motor		Kw	2.2	3
	Battery Voltage /Capacity		V/Ah	24/225	
	Control System			Curtis AC Controller	
	Battery Size		mm	790x210x576	
Other	Electric Power Steering (EPS)			Optional	
	Operator Platform			Optional	

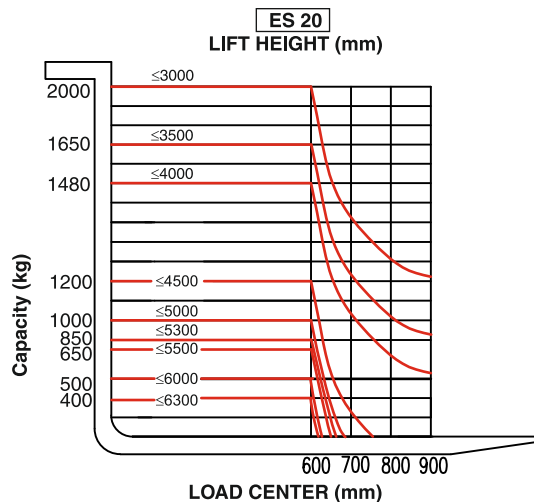
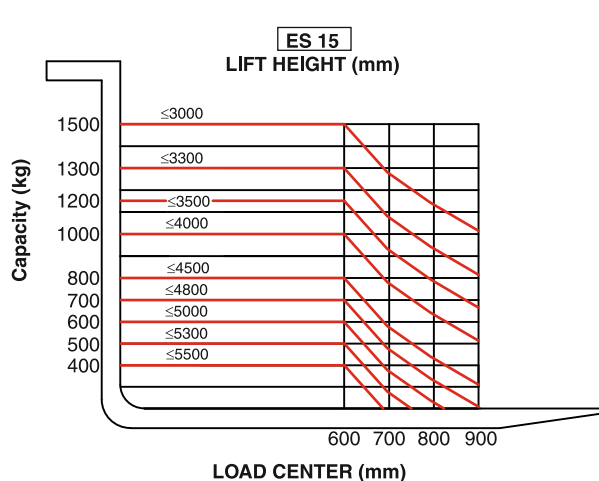

MAST DETAILS FOR ELECTRIC STACKER (ES Model)

MAST TYPE	MAX FORK HEIGHT (mm) h3	LOAD CAPACITY @ MFH (KGS)		MAST LOWERED HEIGHT (mm) h1		MAST EXTENDED HEIGHT (mm) h4		FREE LIFT HEIGHT (mm)		
		ES15	ES20	ES15	ES20	ES15	ES20	ES15	ES20	
DUPLEX	3000	1500	2000	2045	2045	3540	3540	-	-	
	3300	1300	1800	2195	2195	3840	3840	-	-	
	3500	1200	1650	2295	2295	4040	4040	-	-	
	4000	1000	1480	2545	2545	4540	4540	-	-	
TRIPLEX	4500	800	1200	2075	2075	5096	5096	1550	1550	
	5000	600	1000	2245	2245	5595	5595	1716	1716	
	5300	500	850	2345	2345	5895	5895	1816	1816	
	5500	400	650	2415	2415	6095	6095	1884	1884	
	6000	-	500	-	2585	-	6595	-	-	2050
	6300	-	400	-	2685	-	6895	-	-	2150

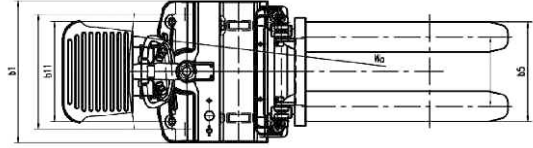
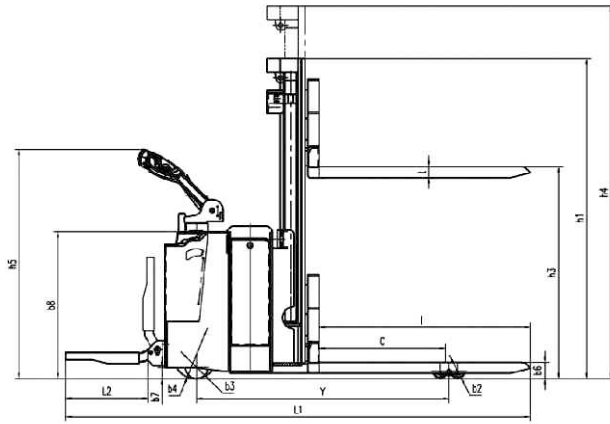

Properties	Model	Unit		ES15	ES20
Wheel	Wheel Type			Polyurethane	Polyurethane
	Size of Front Wheel ϕ	b2	mm	78	78
	Size of Support Wheel ϕ	b3	mm	124	124
	Size of Drive Wheel ϕ	b4	mm	230	230
	Wheel Base	Y	mm	1380	1395
	Wheels, Number Front / Rear(x=Driven Wheels)			1 x +2/4	
Specifications	Lowered Height of Fork	b6	mm	90	
	Rear Body Width	b11	mm	800	850
	Rear Body Length	L2	mm	585	
	Rear Body height	b8	mm	800	
	Height of tiller arm in drive Position Min & Max	h5	mm	1030-1200	
	Overall Length (with/without platform)	l1	mm	2540/2000	2530/1990
	Overall Width	b1	mm	800	990
	Fork Width	E	mm	170	185
	Fork Length	L	mm	1150	
	Width Over Forks	b5	mm	550/685*	
	Ground Clearance	b7	mm	40	
	Aisle Width (Pallets 1000x1200 mm)		mm	2600	2635
	Aisle Width (Pallets 800x1200 mm)		mm	2530	2575
Min Turning Radius	Wa	mm	1578	1637	

*Optional need to check with mktg. H.Q.

Features :

- Articulating polyurethane load wheels for excellent durability, especially on uneven surfaces.
- Regenerative braking.
- **'Battery discharge indicator'** provided to monitor state of charge.
- Electromagnetic brakes.
- AC traction motor.
- Safety belly button switch for operators safety.
- **'EPS'** Electric power steering system for smooth operation while maneuvering in confined area.
- Quick battery change system.



BUILT TO PERFORM



**RELIABLE AND
DEPENDABLE
EFFICIENCY**

NETWORK

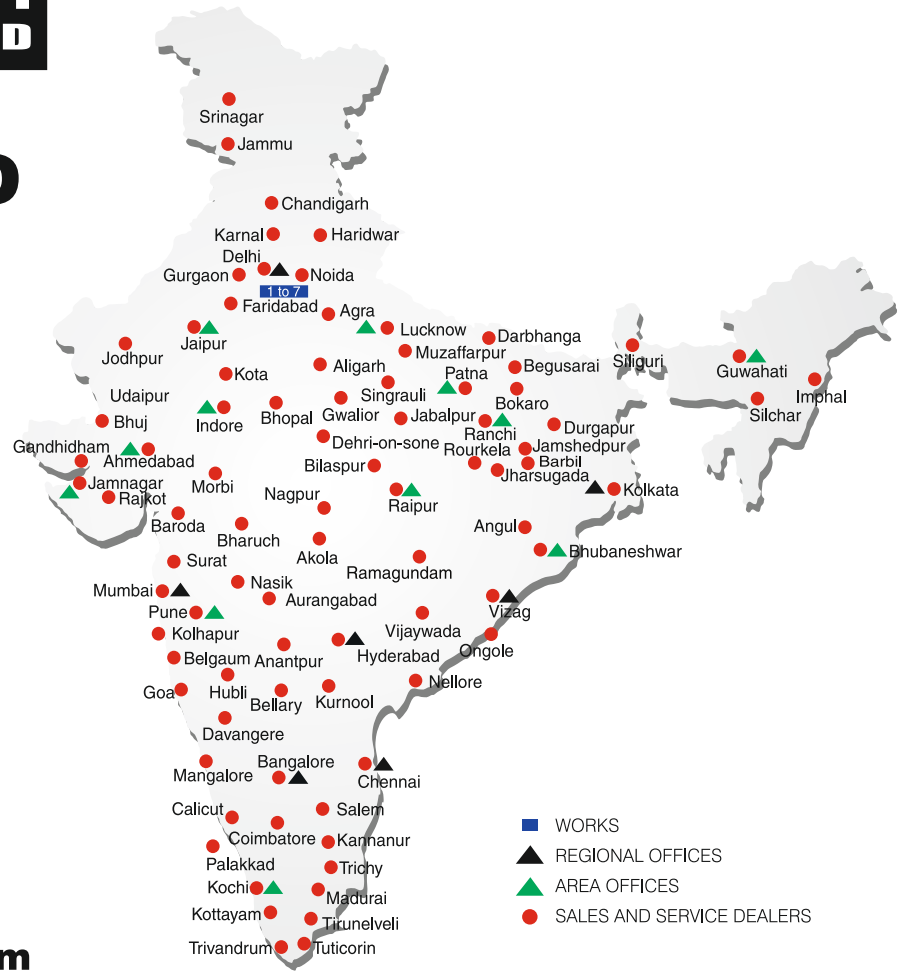

www.ace-cranes.com

MARKETING H.Q.

4th Floor, Pinnacle
Surajkund, NCR-121009
Ph. : +91-129-4550000
Fax : +91-129-4550022
E-mail: marketing@ace-cranes.com

REGISTERED OFFICE

Dudhola Link Road, Dudhola
Palwal-121102, Haryana
Ph.: +91-1275-280111
Fax: +91-1275-280133
CIN : L74899HR1995PLC053860

MUMBAI OFFICE

31, "Kalpataru Court"
Chembur, Mumbai - 400074
Ph.: +91-22-25206846, 25207070
Fax: +91-22-25207071
E-mail: acemumbai@ace-cranes.com

KOLKATA OFFICE

"Forma Towers" 84-A, Second Floor
AJC Bose Road, Kolkata - 700014
Ph.: +91-9038070630
E-mail: acekolkata@ace-cranes.com

CHENNAI OFFICE

1st Floor, "Alsa Regency", 165
Eldams Road, Alwar Pet
Chennai - 600018
Ph.: +91-44-24314253
Fax: +91-44-24314252
E-mail: acechennai@ace-cranes.com

HERE TO SERVE YOU.

SPARE PARTS & SERVICE

ACE has all India Sales and Service network operating out of all the major cities. These outlets are fully equipped to provide genuine spare parts and services by company trained engineers. These outlets are further supported by company officials based at Delhi, Mumbai, Chennai, Kolkatta, Ahmedabad, Surat, Pune, Jaipur, Chandigarh, Ranchi, Raipur, Indore, Bhubneshwar, Lucknow, Jamnagar, Hyderabad, Bangalore, Guwahati, Patna, Vizag & Kochi.



Action Construction Equipment Ltd.

Contact:



ACE reserves the right to alter any specifications without prior notice. Dimensions, weights & capacities mentioned herein are variable by ± 5%. Accessories if shown are not part of the Standard Equipment.