

ACE

Electric Forklifts

Capacity : 1.5-3.0 Tons

High Performance & rugged
Electric Forklift Trucks.

ACE INDIA'S NO. 1
CRANE BRAND





SPECIFICATIONS

Model	Units	AF15E	AF20E	AF25E	AF30E
Power		Battery Power (Electric)			
Load Capacity	kg	1500	2000	2500	3000
Load Center	mm	500			
Fork Size (LxWxT)	mm	920x100x40	1070x100x40	1070x122x40	1070x125x45
Tilt Angle	deg	6° - 12°			
Overall Width	mm	1090	1160	1160	1160
Overhead Guard Clearance	mm	2110	2150	2150	2215
Overall Length	mm	3015	3590	3590	3620
Wheel Base	mm	1250	1475	1475	1610
Ground Clearance	mm	110	125	125	125
Turning Radius	mm	1890	2150	2150	2230
Travel Speed (laden/unladen)	kmph	10/12	10/12	10/12	10/12
Lifting Speed (laden/unladen)	mm/s	300/430	250/300	250/300	156/200
Gradeability	%	16	16	15	12
Operating Weight	kg	2950	4100	4150	4670
Wheel (s)		2/2 (front/ rear) Solid/ Pneumatic			
Tyre Size	Front	6.50x10-10PR	7.00x12-12PR	7.00x12-12PR	7.00x12-12PR
	Rear	5.00x8-10PR	18x7-8-14PR	18x7-8-14PR	18x7-8-14PR
Drive motor	kW	8	8	12	12
Hydraulic Motor	kW	10	10	12	15
Battery Rating	V/Ah	48/440	48/440	48/520	72/330
Electronic Controller		Curtis			

Mast Details

MAST TYPE	MAX FORK HEIGHT (mm)	LOAD CAPACITY AT MFH (KGS)				OVERALL HEIGHT LOWERED (mm)				FREE LIFT (mm)				TILT ANGLE (α-β)
		AF 15E	AF 20E	AF 25E	AF 30E	AF 15E	AF 20E	AF 25E	AF 30E	AF 15E	AF 20E	AF 25E	AF 30E	
Double Mast (Std.)	3000	1500	2000	2500	3000	2000	2035	2050	2050	130	150	150	150	6° / 12°
Double Mast (Fullfree)*	3000	1500	2000	2500	3000	2000	2035	2050	2050	1200	1500	1500	1500	6° / 12°
Double Mast (Std.)	3600	1500	2000	2500	3000	2340	2275	2290	2290	130	150	150	150	6° / 12°
Triple Mast (Fullfree)*	4500	1200	1500/1700**	1550/1750**	1600/1800**	2040	2060	2080	2080	1015	1500	1500	1500	6° / 6°
Triple Mast (Fullfree)	6000	600	800/1000**	850/1050**	900/1100**	2550	2585	2600	2600	1523	1940	1940	1940	3° / 6°

* Suitable for container stuffing

** With front dual wheels

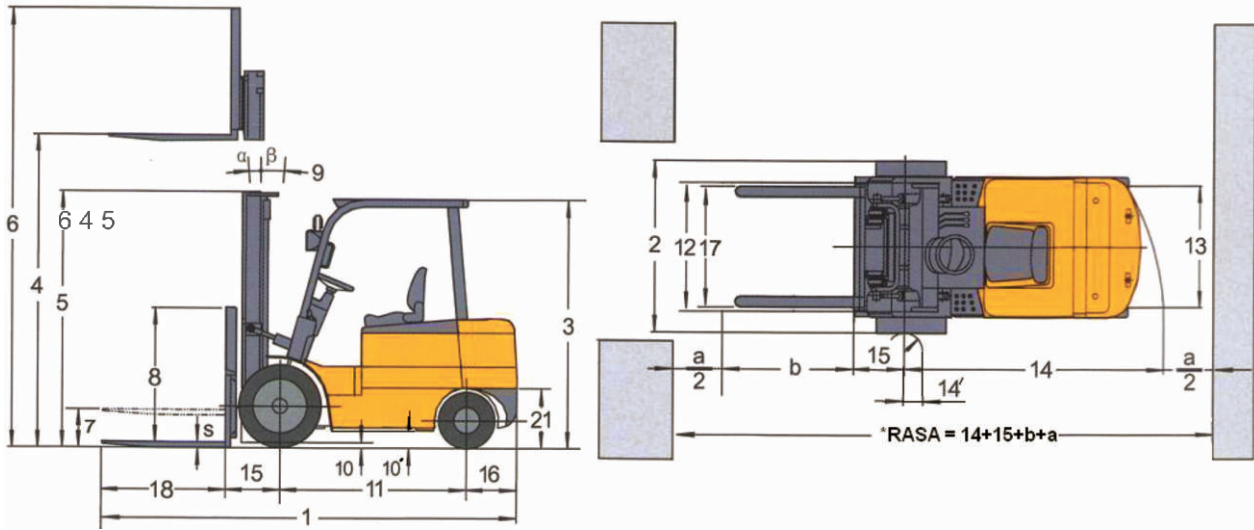

STANDARD DIMENSIONS

	Model	AF15E	AF20E	AF25E	AF30E
		mm	mm	mm	mm
1	Overall Length (with Fork)	3015	3500	3500	3620
2	Overall width	1090	1160	1160	1160
3	Overall Height (Overhead Guard)	2110	2150	2150	2215
4	Lifting Height (std.)	3000			
5	Overall height fork lowered	1995	2060	2060	2060
6	Overall height fork lowered (With Backrest)	4030	4120	4120	4120
7	Free Lift	150	150	150	150
8	Backrest height (from upper face of forks)	960	960	960	1220
9	Tilting Angles	6° ~ 12°			
10	Min. Clearance (bottom of mast)	110	110	110	110
11	Wheel Base	1250	1475	1475	1610
12	Trade (Front)	905	975	975	975
13	Trade (Rear)	920	950	950	950
14	Outside turning radius	1890	2100	2100	2230
15	Front overhung	485	485	485	485
16	Rear overhung	420	430	430	430
17	Lateral fork adjustment	200~950	245~1070	245~1070	245~1070
18	Fork length	920	1070	1070	1070
19	Fork width	100	122	122	125
20	Fork thickness	40	40	40	45
21	Coupler Height	230	230	230	250
22	Min. intersecting aisle	3300	3800	3850	4040

* RASA = Right Angle Stacking Aisle, a = Operator Clearance, b= Load Length



FORKLIFTS

Forklifts

STANDARD EQUIPMENT

- Wide view mast
- Load backrest
- Standard forks
- Power steering
- Retaining rollers
- Overhead guard
- Standard seat (Adjustable)
- Drawbar pin
- Return hydraulic filter
- Battery discharge indicator
- Discharge lift cutoff
- Tilt adjustable steering wheel
- Turn indicator Lights
- Hour meter
- Halogen head lights
- Rear combination lights
- Rear view mirrors
- Reverse buzzer
- Electric horn
- Rubber floor mat
- Tool kit

OPTIONAL EQUIPMENT

- Different Mast Type (Refer Mast Details)
- Extra spool(s) / Hose adaptation package
- Front dual wheels
- Solid tyres
- Non - marking tyres
- Fire extinguisher
- Heavy duty battery
- Safe load indicator
- Blue spot light
- Red safe zone light
- Biometric Access system
- Operator presence system
- Auto greasing system

OPTIONAL ATTACHMENTS

- Fork extensions
- Side shifter
- Hinged forks with bucket
- Paper roll clamp
- Carton clamp
- Rotating forks
- Bale Clamp
- Crane Arm
- Operator Cabin



LOAD CHART

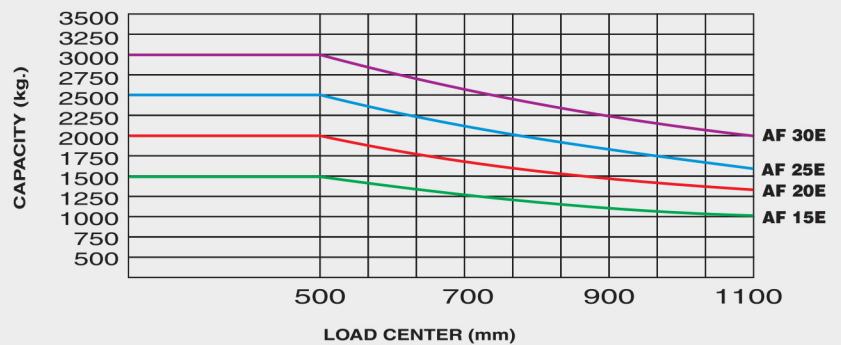

Attachments

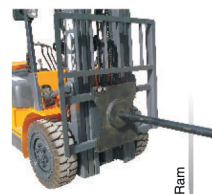



COMPLETE MATERIAL HANDLING SOLUTION

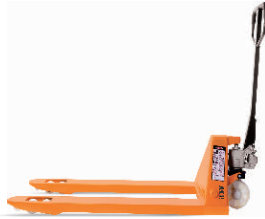

*Nothing beats an **ACE***



Electric Forklifts



1.5T - 3.0T



4.5T - 6.0T

Diesel Forklifts



1.5T - 3.0T



4.0T - 10T



12T - 35T

LPG Forklifts



3.0T - 5.0T

BUILT TO PERFORM



**RELIABLE AND
DEPENDABLE
EFFICIENCY**

NETWORK

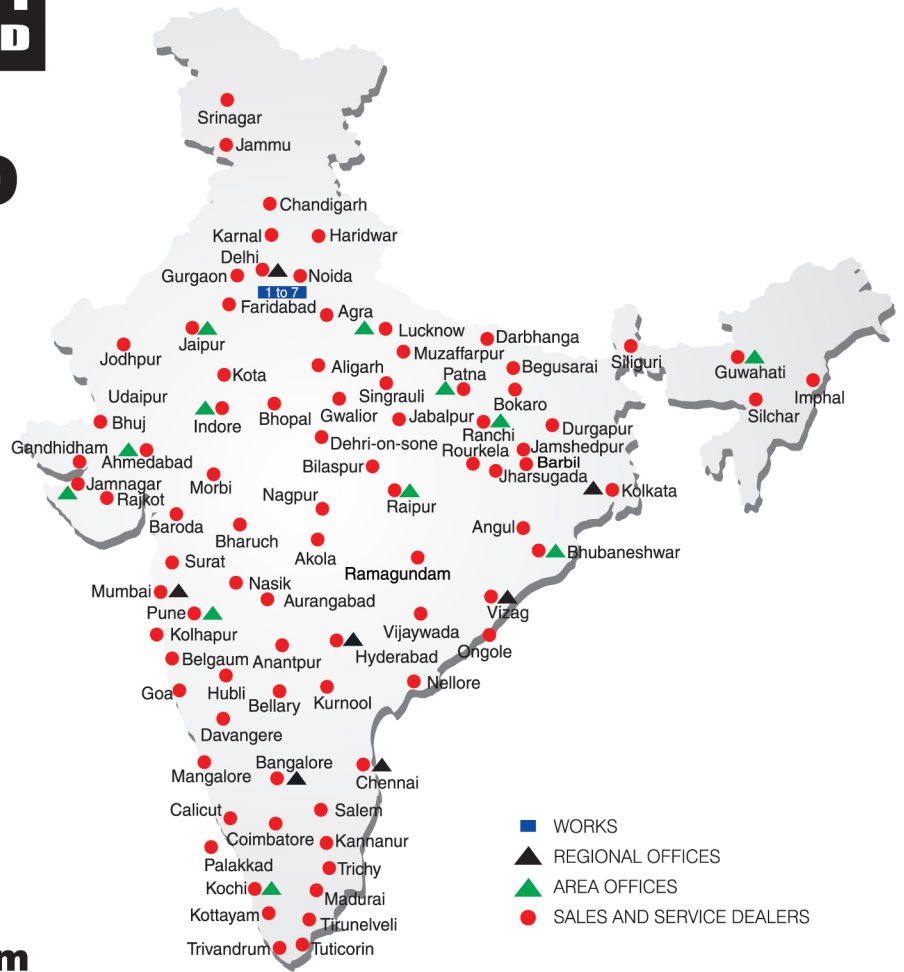

**Toll Free Help Line
1800 1800 004**

www.ace-cranes.com

MARKETING H.Q.

4th Floor, Pinnacle
Surajkund, NCR-121009
Ph. : +91-129-4550000
Fax : +91-129-4550022
E-mail: marketing@ace-cranes.com

REGISTERED OFFICE

Dudhola Link Road, Dudhola
Palwal-121102, Haryana
Ph.: +91-1275-280111
Fax: +91-1275-280133
CIN : L74899HR1995PLC053860

MUMBAI OFFICE

31, "Kalpataru Court"
Chembur, Mumbai - 400074
Ph.: +91-22-25206846, 25207070
Fax: +91-22-25207071
E-mail: acemumbai@ace-cranes.com

KOLKATA OFFICE

"Forma Towers" 84-A, Second Floor
AJC Bose Road, Kolkata - 700014
Ph.: +91-9038070630
E-mail: acekolkata@ace-cranes.com

CHENNAI OFFICE

1st Floor, "Alsa Regency", 165
Eldams Road, Alwar Pet
Chennai - 600018
Ph.: +91-44-24314253
Fax: +91-44-24314252
E-mail: acechennai@ace-cranes.com

HERE TO SERVE YOU.

SPARE PARTS & SERVICE

ACE has all India Sales and Service network operating out of all the major cities. These outlets are fully equipped to provide genuine spare parts and services by company trained engineers. These outlets are further supported by company officials based at Delhi, Mumbai, Chennai, Kolkatta, Ahmedabad, Surat, Pune, Jaipur, Chandigarh, Ranchi, Raipur, Indore, Bhubneshwar, Lucknow, Jamnagar, Hyderabad, Bangalore, Guwahati, Patna, Vizag & Kochi.



Action Construction Equipment Ltd.

Contact:



ACE reserves the right to alter any specifications without prior notice. Dimensions, weights & capacities mentioned herein are variable by ± 5%. Accessories if shown are not part of the Standard Equipment.