

# ACE

## Diesel Forklifts

**Capacity : 1.5-3.0 Tons**

High Performance & rugged  
Diesel Forklift Trucks.

**ACE**

**INDIA'S NO. 1  
CRANE BRAND**





## SPECIFICATIONS

Model		Unit	AF 15D	AF 20D		AF 30D		
Load Capacity		Kg	1500	2000		3000		
Load Center		mm	500					
Power			Diesel					
Tyres			Pneumatic/Solid					
Wheel (s) (F/R)	SD/DD#		2x2 / 4x2					
Brake (s)	Service		Hydraulic-Foot Pedal					
	Parking		Mechanical-Hand Lever					
Fork Size (LxWxT)		mm	920x100x40	1070x122x40		1070x125x45		
Transmission	Number of Speeds - Fwd/Rev		1/1 (Automatic)	1/1 (Automatic) or 2 / 2 (Manual Shift)	2 / 2 (Fluid coupling with Manual Shift)	1/1 (Automatic) or 2 / 2 (Manual Shift)	2 / 2 (Fluid coupling with Manual Shift)	
Speed (s)	Travel (Fwd / Rev)	With Load	Km/h	13.5	17.5	17	18.5	17
		Without Load	Km/h	14.5	20	18	20	18
	Lifting	With Load	mm/s	520	400	400	300	300
		Without Load	mm/s	650	500	500	375	375
	Lowering	With Load	mm/s	450	550	550	560	560
		Without Load	mm/s	550	500	500	350	350
Gradeability (Laden/Unladen)		%	22	19.5/20		18.5/19.5		
Total Weight		Kg	2650	3400	3900	4410	4900	
Weight Distribution (SD/DD)	With Load	Front	Kg	3640	4765	5225	6520	6980
		Rear	Kg	520	635	675	890	920
	Without Load	Front	Kg	1170	1555	1800	1780	2030
		Rear	Kg	1490	1845	2100	2630	2870
Tyre Sizes		Front		6.50-10-10PR	7.00 - 12 - 12PR		28x9-15-12PR	
		Rear		5.00-8-10PR	6.00 - 9 - 10PR		6.50-10-10PR	
Battery	Voltage / Capacity	V / Ah	12/70					
Engine	Rated Horsepower	bhp/rpm	40 bhp @ 2600	49 bhp @ 2650				
	Rated Torque	Nm(Kgm)/rpm	131 / 1800	148 / 1800				
	Number of Cylinders		4					
	Displacement	Ltrs.	2.27	2.54				
	Fuel Tank Capacity	Ltrs.	40	60				
Operating Pressure	For Attachment	Kg / cm <sup>2</sup>	175					

## MAST DETAILS

MAST TYPE	MAX FORK HEIGHT (mm)	LOAD CAPACITY AT MFH (KGS)			OVERALL HEIGHT LOWERED (mm)			FREE LIFT (mm)			TILT ANGLE (α/β)
		AF15D	AF20D	AF30D	AF15D	AF20D	AF30D	AF15D	AF20D	AF30D	
Double Mast (Std.)	3000	1500	2000	3000	2000	2035	2050	130	150	150	6° / 12°
Double Mast (Fullfree)*	3000	1500	2000	3000	2000	2035	2050	1200	1500	1500	6° / 12°
Double Mast (Std.)	3600	1500	2000	3000	2340	2275	2290	130	150	150	6° / 12°
Triple Mast (Fullfree)*	4500	1200	1600 / 1800**	2200 / 2700**	2040	2060	2080	1015	1500	1500	6° / 6°
Triple Mast (Fullfree)	6000	600	800 / 1500**	1050 / 1950**	2550	2585	2600	1523	1940	1940	3° / 6°

\* Suitable for container stuffing  
 \*\* With front dual wheels  
 # SD - Single Drive  
 DD - Dual Drive

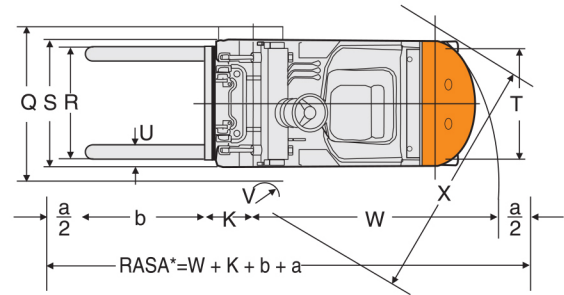
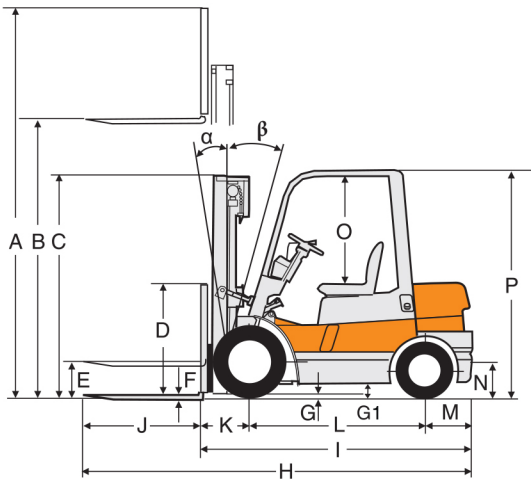

### STANDARD DIMENSIONS

Model	AF15D		AF20D		AF30D	
	mm	mm	mm	mm	mm	mm
	Auto	Auto/Mech	FC	Auto/Mech	FC	
A. Overall height fork raised (with load backrest)	3900	4000	4000	4280	4230	
B. Max. fork height (Standard Model)	3000					
C. Overall height fork lowered (from upper face of forks)	2000	2035	2035	2050	2050	
D. Backrest height (from upper face of forks)	900	1000	1000	1220	1220	
E. Free lift	130	150	150	150	150	
F. Fork thickness	35	40	40	45	45	
G. Min. clearance (bottom of mast)	100	110	110	125	125	
G1. Min. clearance (bottom of chassis)	100	135	135	145	145	
H. Overall length (with forks)	3110	3635	3805	3810	3960	
I. Overall length (without forks)	2190	2565	2735	2740	2890	
J. Fork length	920	1070	1070	1070	1070	
K. Front overhang	400	480	480	495	495	
L. Wheel base	1400	1640	1810	1700	1850	
M. Rear overhang	385	440	440	540	540	
N. Coupler height	220	370	370	370	370	
O. Overhead guard clearance (from face of seat)	970	945	945	945	945	
P. Overall height (overhead guard)	2050	2110	2110	2120	2120	
Q. Overall width (SD/DD)	1080/1580	1215/1670	1215/1670	1220/1680	1220/1680	
R. Lateral fork adjustment (SD/DD)	200~960 200~1340	250~1020 250~1420	250~1020 250~1420	250~1090 250~1440	250~1090 250~1440	
S. Trade (front) (SD/DD)	900/1400	970/1420	970/1420	1000/1460	1000/1460	
T. Trade (Rear)	920	970	970	980	980	
U. Fork width	100	122	122	125	125	
V. Inside turning	450	500	500	550	550	
W. Outside turning Radius (SD/DD)	2040/2500	2210/2650	2450/2850	2500/2950	2700/3150	
X. Min. intersecting aisle	1800	1950	2150	2120	2300	
Y. Tilting angles ( $\alpha$ - $\beta$ )	6° ~ 12°					

\*RASA = Right Angle Stacking Aisle, a = Operator Clearance, b = Load Length



## STANDARD EQUIPMENT

- Wide view mast
- Load backrest
- Standard forks
- Power steering
- Retaining rollers
- Overhead guard
- Standard seat (Adjustable)
- Draw bar pin
- Air cleaner
- Parking brake lever
- Lift, tilt levers
- Dipstick for TC oil
- Lift Circuit cut-off valve
- Overhead air intake
- Tilt adjustable steering wheel
- Turn indicator Lights
- Hour meter
- Water temperature meter
- Fuel meter
- Engine oil pressure warning indicator
- Electric charge indicator
- Halogen head lights
- Rear combination lights
- Rear view mirrors
- Reverse Horn
- Electric horn
- Neutral safety switch (TC)
- Rubber floor mat
- Tool kit
- Inching Control Pedal

## OPTIONAL EQUIPMENT

- Different Mast Type (Refer Mast Details)
- Front dual wheels
- Non Marking Tyres/Solid Tyres
- Fire extinguisher
- All weather steel cabin
- Mechanical transmission
- Spark arrester
- Catalytic converter
- Water muffler
- LPG fuel package with water cooled petrol engine (50 HP @ 2800 rpm)
- Simpson Engine (4 Cylinder S433)
  - Rated Power - 48bhp@2200 RPM
  - Rated Torque - 196.2 N-m@1200 RPM
  - Displacement-3.3lit

## OPTIONAL ATTACHMENTS

- Bale clamp
- Cabin
- Crane attachment
- Drum(s) handling attachment
- Fork extensions
- Fork rotator
- Furnace kit
- Side Shifter
- Side shifter cum fork positioner
- Paper roll clamp
- Ram attachment
- Shovel attachment

## LOAD CHART

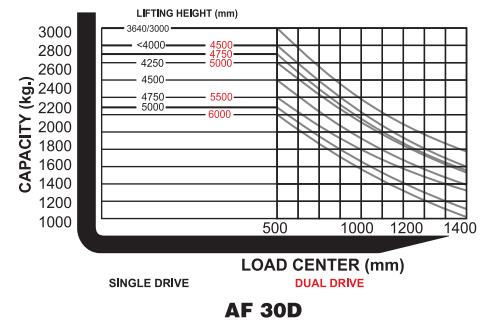
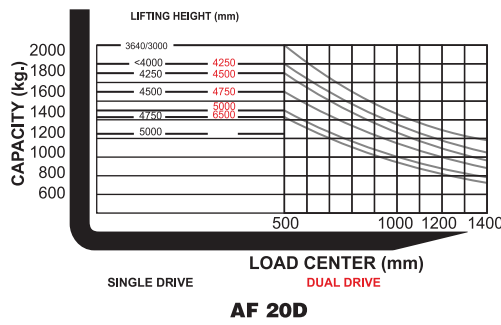
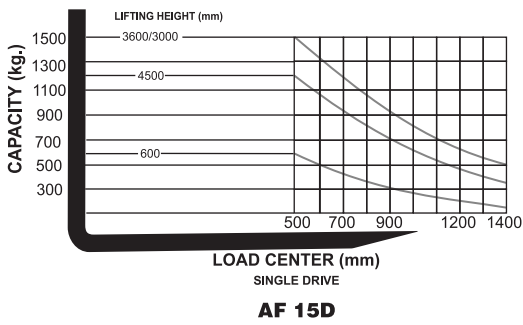

## Attachments

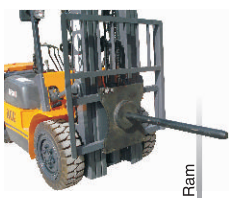
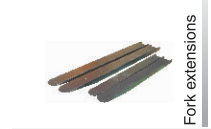



# COMPLETE MATERIAL HANDLING SOLUTION

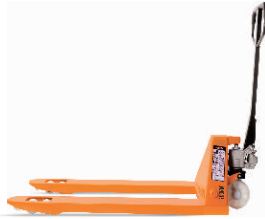

*Nothing beats an **ACE***



## Electric Forklifts



1.5T - 3.0T



4.5T - 6.0T



1.5T - 3.0T



4.0T - 10T



12T - 35T

## LPG Forklifts



3.0T - 5.0T

## Diesel Forklifts

# BUILT TO PERFORM



**RELIABLE AND  
DEPENDABLE  
EFFICIENCY**

## NETWORK

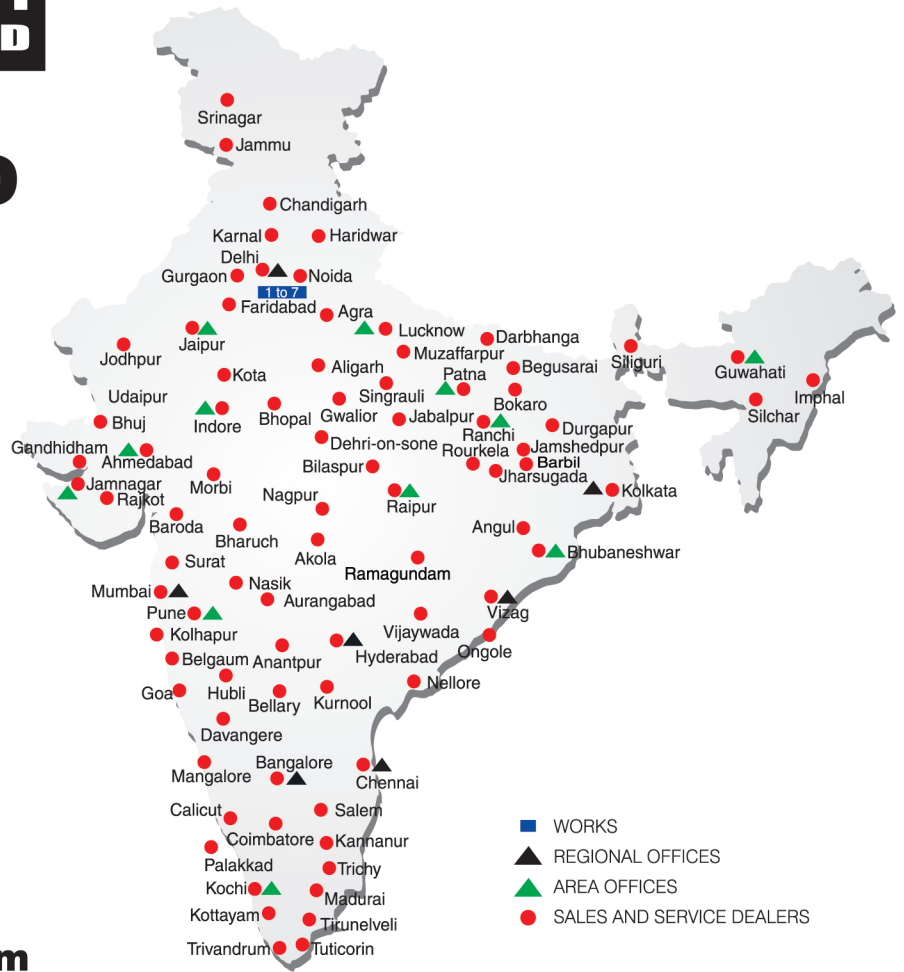

**Toll Free Help Line  
1800 1800 004**

[www.ace-cranes.com](http://www.ace-cranes.com)

### MARKETING H.Q.

4th Floor, Pinnacle  
Surajkund, NCR-121009  
Ph. : +91-129-4550000  
Fax : +91-129-4550022  
E-mail: marketing@ace-cranes.com

### REGISTERED OFFICE

Dudhola Link Road, Dudhola  
Palwal-121102, Haryana  
Ph.: +91-1275-280111  
Fax: +91-1275-280133  
CIN : L74899HR1995PLC053860

### MUMBAI OFFICE

31, "Kalpataru Court"  
Chembur, Mumbai - 400074  
Ph.: +91-22-25206846, 25207070  
Fax: +91-22-25207071  
E-mail: acemumbai@ace-cranes.com

### KOLKATA OFFICE

"Forma Towers" 84-A, Second Floor  
AJC Bose Road, Kolkata - 700014  
Ph.: +91-9038070630  
E-mail: acekolkata@ace-cranes.com

### CHENNAI OFFICE

1st Floor, "Alsa Regency", 165  
Eldams Road, Alwar Pet  
Chennai - 600018  
Ph.: +91-44-24314253  
Fax: +91-44-24314252  
E-mail: acechennai@ace-cranes.com

## HERE TO SERVE YOU.

### SPARE PARTS & SERVICE

ACE has all India Sales and Service network operating out of all the major cities. These outlets are fully equipped to provide genuine spare parts and services by company trained engineers. These outlets are further supported by company officials based at Delhi, Mumbai, Chennai, Kolkatta, Ahmedabad, Surat, Pune, Jaipur, Chandigarh, Ranchi, Raipur, Indore, Bhubneshwar, Lucknow, Jamnagar, Hyderabad, Bangalore, Guwahati, Patna, Vizag & Kochi.



**Action Construction Equipment Ltd.**

Contact:



ACE reserves the right to alter any specifications without prior notice. Dimensions, weights & capacities mentioned herein are variable by ± 5%. Accessories if shown are not part of the Standard Equipment.